

Compact, Light Weight, High Power Output

I-K Coreless Motor

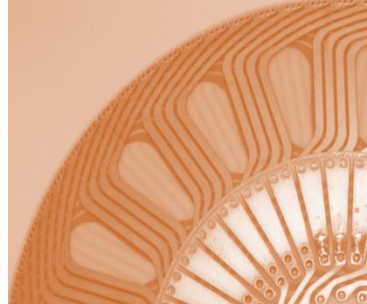

We developed the coreless brush motor for the electric brush cutter that requires the high output. This motor is manufactured by the general-purpose machine without the special equipment. This coreless motor is made up of the magnetic circuit of 10 poles and the armature circuit designed by our own specific technology. The armature circuit is designed by the multilayer printed circuit board produced by the specific manufacturing technology. As the next-generation power which changes to a small engine, this motor is available for not only the brush cutters but also the industrial equipment such as the tree-plating equipment and the air conditioner.

For electric brush cutter



For general use

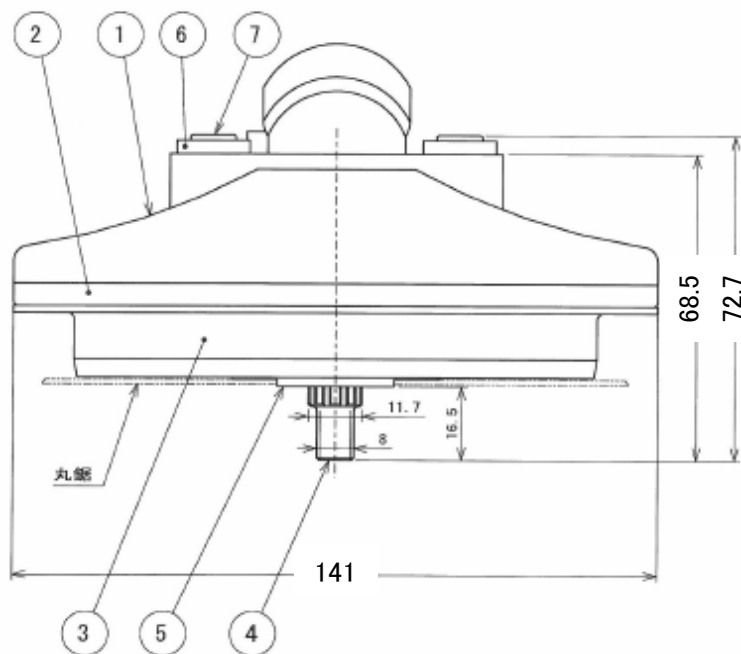

1	2	3	4	5	6	7
Upper case of motor	Lower case of motor	Fan cover	Shaft	Upper metal fitting on the circular saw	Brush holder	Brush cap

This motor is controlled by the converter for exclusive use. (about 250W~400W) For further information, Please refer to the characteristic table of the motor or contact us by e-mail or phone call. Not only any specifications concerning the power output and the number of poles but also any quantities between the prototype and the mass production can correspond to your demand.

Cosmo Mechanics Co., Ltd.

〒078-8235
5-4-2-11 Toyooka,
Asahikawa, Hokkaido, Japan

TEL: +81-166-34-8891
FAX: +81-166-34-8895

general@cosmo-mk.co.jp
<http://www.cosmo-mk.co.jp>

Parts Number	CMO3BA350I1
Rated Output	350W (High output type is negotiable)
Diameter	φ141mm
Shaft	φ8mm
Weight	About 890g (without Fan cover, etc.)
Speed	3,500~6,000rpm
Control	Converter for exclusive use